

SERVICE MANUAL

**MOYNO<sup>®</sup>**  
**Vertical Pump**



**MOYNO**

*Always the Right Solution™*

## TABLE OF CONTENTS

1-1	INTRODUCTION.....	1
1-2	General.....	1
1-3	Nameplate Data.....	1
1-4	Pump Rotation.....	1
1-5	Model Number.....	1
1-6	Frame Size Designation.....	1
1-7	Type Designation.....	1
1-8	Trim Code.....	2
1-9	Variation of Standard Parts.....	2
2-1	INSTALLATION.....	2
2-2	General.....	2
2-3	Lifting.....	2
2-4	Single Point.....	2
2-5	Piping.....	2
2-6	Discharge Piping.....	2
2-7	Foundation.....	2
3-1	OPERATION.....	2
3-2	Initial Check.....	2
3-3	Start-up.....	2
4-1	MAINTENANCE.....	2
4-2	General.....	2
4-3	Lubrication.....	2
4-4	Bearings.....	3
4-5	Pin Joints.....	3
4-6	Mechanical Seal.....	3
4-7	Mechanical Seal Removal/Replacement.....	3
4-8	Disassembly.....	3
4-9	Stator/Extension Tube/Rotor Removal.....	4
4-10	Drive Shaft Removal.....	4
4-11	Assembly.....	4
4-12	Rotor/Stator to Connecting Rod Assembly.....	4
4-13	Drive Shaft/Extension Tube/Discharge Housing Assembly.....	5
4-14	Mechanical Seal/Drive End Assembly.....	6
4-15	Final Assembly.....	6
4-16	Storage.....	6
4-17	Standard Hardware.....	7
4-18	Parts List.....	10

SERVICE MANUAL

# Moyno® Vertical Pumps

## 1-1. INTRODUCTION

### 1-2. GENERAL

The Moyno® Vertical Pump is the culmination of more than 70 years of experience in manufacturing and marketing fluids handling equipment. This rugged pump has been engineered to be the most reliable product ever sold under the Moyno name. The pump has been painstakingly tested to assure consistent performance in the most difficult of applications. It represents the next generation of the world's most versatile pump.

The Moyno® Vertical Pump is a progressing cavity pump. A single helical rotor rolling eccentrically in the double helix of the stator creates the pumping action. The rotor in conjunction with the stator forms a series of sealed cavities 180 degrees apart. As the rotor turns, the cavities progress from the suction to the discharge end of the pump. As one cavity diminishes, the opposing cavity increases at exactly the same rate. Thus, the sum of the two discharges is a constant volume. The result is a pulsation-free positive displacement flow utilizing no valves.

1-3. Nameplate Data. The pump nameplate, located on the drive adapter, contains important information relating to the operation and servicing of the pump. This information includes the direction of rotation arrow and the pump model and serial numbers (see Figure 1-1). The pump model number must be used for reference when ordering spare parts.

1-4. Pump Rotation. A rotation arrow on the nameplate indicates the direction of rotation. Normal rotation of Moyno® Vertical Pumps is **counterclockwise**, when viewed looking down on the pump drive shaft or from left to right, when looking at the drive shaft through the opening of the drive adapter.

1-5. Model Number. The pump model number consists of three component parts: Frame Designation, Type Designation and a Trim Code. A typical model number, for example, might be V1J119 SSQ3SAA, as shown on the nameplate in Figure 1-1.

1-6. Frame Designation. The Moyno® Vertical Pump is modular in concept allowing for optimal matching of drive ends and pump elements (rotor and stator) to meet the requirements of the application. The five or more characters in the frame designation describe the particular combination of drive end and pump elements, as well as other construction details of your pump.

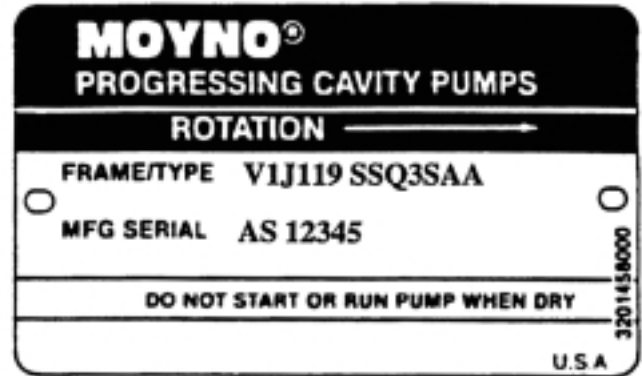

Figure 1-1. Typical nameplate showing rotation arrow, model and manufacturing serial numbers.

The first character in the frame designation, always a V, indicates the vertical series.

The second character is always a number and indicates the number of stages of pumping element.

The third character is always a letter and indicates the pumping elements.

The fourth, fifth and sixth characters are always numbers, indicating the length in inches from the bottom of the standard mounting flange to the end of the suction. The fractional portion of the length is truncated for simplification.

1-7. Type Designation. Following the Frame Designation is the Type Designation, a series of three letters describing the materials from which the pump is constructed, followed by a number indicating the product revision level.

The first letter identifies the material of the discharge housing, extension tubes, and stator tube.

- C Cast Iron
- S 316 Stainless Steel
- W Cast Steel
- X Special to application

Note: The drive adapter of the pump is always made of carbon steel.

The second letter indicates the material used in the drive shaft, connecting rod, rotor, and other wettable parts.

- D Alloy Steel
- G 416 Stainless Steel
- J 17-4 pH Stainless Steel
- S 316 Stainless Steel
- X Special to application

The third letter indicates the material of the stator. It identifies only the stator material and not that of the tube, in which the stator is placed. Standard stator materials used in the Moyno pump are as follows:

- B EPDM 300, 70 Durometer
- C Nitrile 103, 50 Durometer
- E Nitrile 110, 70 Durometer
- F Fluoroelastomer 500, 75 Durometer
- K Hypalon 800, 70 Durometer•
- M Nitrile 100M 70 Durometer
- P Thiokol 70 Durometer•
- Q Nitrile 100, 70 Durometer
- R Natural Rubber 200, 55 Durometer
- U Urethane 70 Durometer
- X Special to Application
- Z White Nitrile 150, 70 Durometer

A typical type designation, such as SDQ, would identify the following materials of construction:

- S = Stainless discharge housing, extension tube, and stator tube.
- D = Alloy steel rotor, connecting rod and other minor metallic parts in contact with the fluid being pumped.
- Q = Nitrile (70 durometer) stator

- Hypalon and Teflon are trademarks of E.I. DuPont de Nemours and Company
- Thiokol is a trademark of Morton Thiokol Inc.

1-8. Trim Code. The product revision level is usually 3, indicating the latest U.S. design. Also included in the Model Number is the three character Trim Code which is used to identify pump construction. The letters "SAA" signify standard construction, with letters other than these signifying variations. The first letter identifies sealing variations; the second, internal variations; and the third, rotor variations.

1-9. Variations of Standard Parts. If the trim code of your pump is other than "SAA," contact your nearest Moyno representative for clarification. Do not modify your pump with any variation unless you have determined that it is compatible with your application.

## 2-1. INSTALLATION

### 2-2. GENERAL

Moyno pumps are lubricated and tested at the factory prior to shipment and require minimum pre-start up maintenance.

Accessibility to the pump and adequate clearance should be a prime consideration in any installation. Enough space should surround the unit so that maintenance can be carried out with ease.

### 2-3. Lifting

2-4. The unit should only be lifted from a single point lift over head. There are three threaded holes in the mounting flange where eyebolts can be installed.

With a chain, lift the unit from eyebolts. You can also wrap a chain around the drive adapter and gently lift and lower into position. **Never lift unit by the drive lifting eyes.**

### 2-5. PIPING

2-6. Discharge Piping. The diameter should generally be as large as the pump ports unless fluid conditions indicate otherwise.

### 2-7. FOUNDATION

Each unit should be rigidly mounted on a strong, fabricated steel frame. This frame should be mounted on a concrete foundation. The foundation should be approximately 4" to 8" larger in diameter than the mounting flange.

**CAUTION: In order to prevent vibration and ensure the safe operation of the unit, it is important that the unit be mounted on a rigid foundation.**

## 3-1. OPERATION

### 3-2. INITIAL CHECK

Before putting the pump into operation, the following items should be checked to ensure that each piece of equipment is installed correctly:

- Electrical Connections.
- Gauges and other instruments
- Pump rotation. Normal rotation is indicated on the nameplate on the drive adapter.
- All valves on the discharge side of the pump should be open, including the throttle valve on the seal housing.

**CAUTION: This is a positive displacement pump. Do not operate it against a closed valve.**

### 3-3. START-UP

**CAUTION: DRY OPERATION IS HARMFUL TO THE PUMP! Never allow the pump to operate without liquid, as dry operation will cause premature wear of the stator and possible damage. The stator is lubricated by the liquid, which is pumped.**

1. Once the pump has been properly installed and the sump is filled with liquid, check for direction of pump rotation by momentarily starting and stopping the drive. Check rotation arrow on pump nameplate for correct rotation. The pump shaft should rotate from left to right while viewing the shaft through the drive adapter or counter-clockwise from above the seal housing.

2. Start pump.

## 4-1. MAINTENANCE

**Note:** Refer to the parts list for part name and identification.

**4-2. General.** The Moyno® Vertical Pump has been designed for a minimum amount of maintenance. The pump is one of the easiest to work on and requires few tools to disassemble.

### 4-3. Lubrication

4-4. Bearings. The bearings in the gearbox are lubricated at the factory. Refer to gearbox lubrication instructions.

4-5. Pin Joints. The pin joints are lubricated at the factory and only need to be re-lubricated when the joints are disassembled and reassembled.

4-6. Mechanical Seal. The standard single mechanical seal is designed with recirculation from seal chamber through an orifice and back through the standard mounting flange. Depending upon the discharge pressure, it may be necessary to throttle the recirculation flow. This design is recommended for relatively clean fluids.

#### 4-7. Mechanical Seal Removal/Replacement. (Without Removing Unit from the tank)

1. Slide the shaft collar (5) back and push the drive pin (6) from between the gear motor (1) and drive shaft (7). The drive shaft may slip down some – it is being held by shaft collar (14). It will be raised by the drive shaft lift kit (included). Disconnect the hex screws holding the gear motor to the drive adapter (2) and remove the gear motor.

2. Remove the hex cap screws holding the seal housing (16) to the seal adapter plate (8). Carefully slide the seal housing up and off the drive shaft, being careful not to damage the seal faces.

3. Remove the stationary portion of the seal from the seal housing. Remove the O-ring (10) from the seal housing.

4. If replacing the seal, scribe a mark on the drive shaft at the location of the seal drive collar. Slide the rotary portion of the seal off the drive shaft.

5. Inspect all faces and O-rings of the seal and seal area. Replace all damaged seal components.

6. Place the O-ring (10) over the end of the seal housing and slide the seal housing back over the drive shaft. Be careful not to damage the faces when dropping the seal housing onto the seal adapter plate. Insert the hex cap screws to secure the seal housing to the seal adapter plate – do not completely tighten at this time.

7. Slide the shaft collar onto the drive shaft with the counter-bored side face up, toward the gear motor.

8. Install the gear motor – be sure to align the holes in the gear motor and the drive shaft before dropping the gear motor in place. **CAUTION** – excessive axial force on the pump drive shaft may shift it beyond the limitation of the lift kit. Insert and tighten the bolts to connect the gear motor to the drive adapter.

9. If the drive shaft has shifted down too far to move upward with a punch, the drive shaft lift kit must be used. If the holes are aligned enough to insert the drive pin, skip to step 14.

10. Lift kit use – refer to Figure 4-1 below. Insert both lift plates vertically through the drive adapter with the open section towards the seal housing. Flip the open side of each plate toward the drive shaft. The two plates should form a rectangle that now surrounds the drive shaft. For now, allow the two plates to rest between the shaft collar and the seal housing.

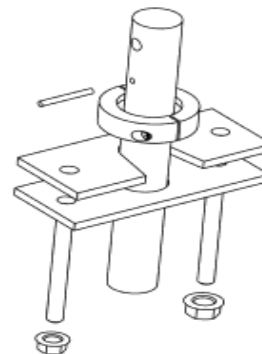

Figure 4-1. Lift Kit

11. Insert the small dowel pin through the hole in the drive shaft (below the gear motor drive pin). Slide the shaft collar up to the dowel pin and lock it down.

12. Insert the two studs into the top of the drive adapter. Move the two lift plates up toward the shaft collar while inserting the studs through the holes of the lift plates. Thread a hex nut onto each stud until the lifting plates contact the shaft collar.

13. Tighten each nut alternately – do not overtighten one side causing a bind on the drive shaft – until the drive shaft and gear motor holes align enough to insert the drive pin.

14. Insert the drive pin, tapered end first, through the aligned holes. Some tapping may be required. If the lift kit was used, remove it now in reverse order of steps 10-13.

15. Move the shaft collar up to the drive pin, covering half of the drive pin. This will insure that the drive pin does not slip out during operation. Secure the shaft collar to the drive shaft.

16. Tighten the hex cap screws to secure the seal housing to the seal adapter plate. The new mechanical seal is now set.

#### 4-8. Disassembly.

1. Flush the pump (preferably with clean water) to remove the pumpage from the unit.

Run unit in reverse for approximately 30 seconds to drain the extension tube.

2. Close suction and discharge valves.

3. Disconnect power source and lock out the circuit breaker.

4. Disconnect the discharge piping and unbolt the mounting flange from the pump support. Secure a chain to the eyebolts or around the drive adapter and lift the entire pump assembly from the sump with a single point lifting mechanism from over head. Lay the unit on its side and block from rolling.

#### 4-9 Stator/Extension Tube/Rotor Removal

1. Remove the SQ hex screws (G) and lock washers connecting the clamp ring (32) to the extension tube (18). Pull the stator off the rotor (28).

Remove the retaining ring (31) and clamp ring.

2. Remove the hex screws (F), nuts, and lock washers connecting the extension tube (18) to the extension tube (17). Pull the extension tube (18) over the rotor/connecting rod assembly.

Remove the stator gasket (30).

3. Loosen the screws in the shaft collar (14) and slide it away exposing the drive pin (12).

Tap the drive pin out of the drive shaft (7).

Pull the rotor/connecting rod/shaft head away from the drive shaft. Place the assembly in a vise for further disassembly.

4. Remove the retaining ring (25) from its groove in the shaft head (13). Slide the pin retaining ring (23) towards the groove and push the pin joint seal (27) off the end of the shaft head and slide it up the connecting rod (22).

Remove the o-ring (26). Slide the pin joint retainer off the shaft head onto the connecting rod. Push the drive pin (24) out of the shaft head.

Pull the shaft head off the connecting rod.

Repeat step four for the rotor side of the connecting rod.

Slide both the pin joint retainers and pin joint seals off the connecting rod.

#### 4-10. Drive Shaft Removal.

1. Loosen the screws in the shaft collar (5) and slide it down exposing the drive pin (6). Push the drive pin out of the drive shaft (7).

2. Remove the four hex screws (A) and washers connecting the gear motor (1) to the drive adapter (2). Pull the gear motor away from the drive adapter.

3. Slide the shaft collar (5) off the drive shaft. Remove the screws (D) holding the seal housing (16) to the seal adapter plate (8). Slide the seal housing off the drive shaft. Be careful not to damage the mechanical seal (15). Remove the o-ring.

Refer to the mechanical seal removal/replacement section 4-7 for instructions.

4. Remove the six hex screws (B) and lock washers holding the drive adapter (2) to the discharge housing (3). Pull the adapter away from the housing. Remove four hex screws connecting the seal adapter plate (8) to the drive adapter. Remove the o-ring (9).

5. Remove the hex screws (C) connecting the discharge housing (3) to the mounting flange (4). Pull the housing away.

6. Remove the retaining ring (11) from the discharge housing. Remove the O-ring (9).

7. Unbolt all extension tubes (17) and slide them off the drive shaft (7).

Pull each bearing flange (20) from the end of each extension tube and remove the o-ring (19).

Press the shaft bushing (21) from each bearing flange.

Slide the drive shaft (7) out of the extension tubes.

8. Remove the hex screws ® connecting the extension tube (17) to the mounting flange (4).

#### 4.11 Assembly

Re-assembly the unit is reverse order of disassembly. Follow the general guidelines below.

#### 4-12. Rotor/Stator to Connecting Rod Assembly

1. Slip stator clamp ring (32) onto the end of the stator (29) and install retaining ring (31) in groove provided on the end of the stator.

2. Coat the rotor (28) contour with waterless hand cleaner, glycol, or other lubricant compatible with the stator elastomer. Insert the rotor into the stator about half the length of the stator.

**Note: Turning the rotor counter-clockwise while inserting into stator will ease assembly.**

3. Slide the retaining ring (25) up onto the rotor head back near the beginning of the contour. Slide the O-ring (26) onto its groove on the rotor head.

4. Push both pin joint seals (27), one on each end, onto the connecting rod (22). The small diameter neck portion of the seal should be pushed on first. Applying a small amount of grease to both surfaces will ease assembly. Once on the connecting rod, slide both pin joint seals toward the center of the connecting rod.

5. Slide the pin joint retainer (23) on one end of the connecting rod – be sure the chamfered end faces the pin joint seal, they should fit snugly together.

6. Apply a liberal amount of grease to the end of the connecting rod and inside the recess in the rotor head. Insert the end of the rod inside the rotor head. Align the holes and push the drive pin (24) into place. Move the joint around to push out the excess grease. Wipe away the excess grease.

7. Slide the pin retaining ring (23) over the drive pin pass the large groove on the front of the rotor head. Slide the pin joint seal towards the rotor head and into the groove – the back of the pin joint seal should fit into a small groove on the connecting rod. Push the pin retaining ring back towards the pin joint seal.

8. Install the retaining ring (25) in its groove.

9. Slide the retaining ring (25) onto the shaft head (13) back near the end. Slide the O-ring (26) onto its groove on the shaft head (13).

10. Slide the pin joint retainer ring (23) on the end of the connecting rod (22) – be sure that the chamfered end faces the pin joint seal, they should fit snugly together.

11. Apply a liberal amount of grease to the end of the connecting rod and inside the recess in the shaft head. Place the shaft head onto the connecting rod end and align the holes. Push the drive pin (24) into place. Move the joint around to push out the excess grease. Wipe away the excess grease.

12. Slide the pin retaining ring (23) over the drive pin pass the large groove on the front of the shaft head. Slide the pin joint seal towards the joint and into this groove – the back of the pin joint seal should fit into a small groove on the connecting rod. Push the pin retaining ring back towards the pin joint seal.

13. Install the retaining ring in its groove.

#### 4.13 Drive Shaft/Extension Tube/Discharge Housing Assembly

1. Lay out all of the extension tubes and bearing flanges. There should be the same amount of both components. The extension tubes should progress from longest to shortest from the mounting flange to the stator. If two extension tubes are the same lengths then they can be used interchangeably. The shortest extension tube will cover the connecting rod and connect the stator to the other extension tubes. Set this short one aside, it will not be used until final assembly.

The ends of the extension tubes look alike, however, they are different. It is important that

you install the proper ends together to assure the O-rings seal.

Regardless of how many long extension tubes you have, the flange end with the O-ring groove must be installed facing up toward the discharge. See Figure 4-2.

#### End with O-Ring Groove

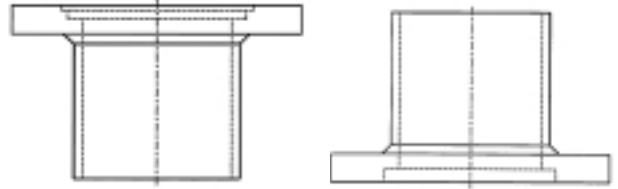

Figure 4-2.

2. Press all shaft bushings (21) into all bearing flanges (20).

3. Gently slide the drive shaft (7) into the longest extension tube (17).

4. Slide one bearing flange with bushing onto the drive shaft, extending beyond the discharge side of the extension tube (17). Slide it up and into the recess in the extension tube. Place the O-ring (19) around the bearing flange.

5. Install the retaining ring (11) into the groove in the mounting flange (4). Bolt the mounting flange to the extension tube (17) with six hex screws (E) and lock washers.

6. Place the O-ring (9) onto the end of the discharge housing (3) and bolt the discharge housing to the mounting flange with six hex head screws (C) and lock washers. Be sure to locate the discharge port in the proper position with the mounting flange. The window in the drive adapter should line up with the circulation connection on the mounting flange. Slide the drive shaft (7) up until it extends beyond the discharge housing, approximately 12 inches.

7. Slide a bearing flange with bushing onto the other end of the drive shaft extending out of the extension tube. If this is the last bearing flange, than skip to section 4-14; if not than continue with this section.

8. Slide the bearing flange into the recess of the extension tube. Place an O-ring (19) around the bearing flange.

9. Slide the next longest (or equal length) extension tube over the drive shaft. The bearing flange should slide right into the recess of the mating extension tube. Secure the two extension tubes with six hex screws and lock washers.

10. Repeat steps 7-9 until all bearing flanges are used and only the shortest extension tube is remaining. Move onto to Section 4-14.

#### 4-14. Mechanical Seal/Drive End Assembly

1. Place the O-ring (9) into the groove on the seal adapter plate (8) and attach it to the drive adapter (2) with four hex screws.

2. Push the seal adapter plate/drive adapter assembly into the recess in the discharge housing (3). The window in the drive adapter should line up with the circulation connection on the mounting flange. Secure in place with six hex screws (B), lock washers, and hex nuts.

3. Place the O-ring (10) into the groove on the seal housing (16) and slide the assembly over the end of the drive shaft and into position against the seal adapter plate. Fasten in place with four hex cap screws (D) and lock washers.

4. Place the gear motor (1) against the drive adapter flange. Align the two shafts so that the gearmotor shaft fits inside the end of the drive shaft and the holes are aligned. Secure the gearmotor with four hex screws (A) and lock washers.

5. Push the drive pin (6) through the hole tapered end first. The drive pin may require some tapping.

6. Through the opening in the adapter/housing, mark the drive shaft at the position where it aligns with the top of the seal housing. Also, at the last bearing flange (20), mark the drive shaft on the discharge side of the bearing flange at the position where the drive shaft aligns with the bearing flange (20). You will need these reference marks to position both the mechanical seal (15) and shaft collar (5) on the drive shaft.

7. Push the drive pin (6) out of the drive shaft.

8. Remove the hex screws and gearmotor. Remove the hex screws and slide the seal housing off the drive shaft.

9. Pull the last bearing flange off the drive shaft. Push the drive shaft so it extends beyond the end of the last extension tube assembly about 12 inches.

10. Measure 0.125 - 0.25 inches from your mark, up the drive shaft towards the discharge housing. Slide the shaft collar (5), up to the drive shaft to the discharge side of the new mark. Secure the shaft collar with two hex screws.

11. Push the drive shaft toward the gear motor end until the original mark on the drive shaft approaches the entrance to the last extension tube assembly. Place the bearing flange (20) back on the drive shaft and into the recess in the extension tube assembly. Place the O-ring (19) around the bearing flange.

12. Gently push the stationary portion of the mechanical seal (15) into the bore in the seal housing (16). **Be careful not to touch the face.**

13. Refer to your mechanical seal drawing to determine where to position the rotating seal component from the top of the seal housing. Measure down from the mark on the drive shaft and secure the rotating seal to the drive shaft by tightening the set screws.

14. Carefully slide the seal housing on the drive shaft and secure it to the seal adapter plate.

15. Reattach the shaft collar (5) with counter bored toward gear motor, the gear motor, and the drive pin. Be sure the counter-bore in the shaft collar covers half of the drive pin to insure that the drive pin does not slip out during operation. Secure the shaft collar to the drive shaft. You will have to push on the end of the drive shaft to align the holes.

#### 4-15. Final Assembly

1. Place the stator gasket (30) in the recess in the end of the extension tube (18).

2. Slide the shortest extension tube (18) over the connecting rod/pin joint assembly and position on the end of the stator (29). **Be careful not to damage the stator gasket.** The end of the extension tube which has threaded holes in the flange should be positioned towards the stator. Secure the extension tube in place with six hex screws (G) and lock washers.

3. Position the entire assembly against the drive shaft/extension tube/discharge housing assembly.

4. Place the two halves of the shaft collar (14) together and loosely secure with two hex screws. Slide the shaft collar over the end of the drive shaft.

5. Insert the shaft head into the end of the drive shaft. Align the holes.

6. Push the drive pin (12) into the hole and secure the shaft collar (14) over the drive pin.

7. Align the holes in the extension tube flanges and pull the two flanges together. You can use longer bolts if necessary. **Be careful not to damage the mechanical seal faces.** Secure the two flanges together with six hex screws (F), lock washers, and nuts.

#### 4-16. Storage

1. Store pump inside and away from moisture.

2. Remove all drain plugs and liquid from unit.

3. See drive manufacturer's instructions for motor/gear storage.

4. Apply a rust inhibitor to all unpainted iron surfaces.

4-17. Standard Hardware

Ref No.	Description	F, G	Qty	H, J, K, L	Qty
A	Hex Screw Lock Washer	1/2-13 X 1-1/4 1/2	5 5	1/2-13 X 1-1/2 1/2	4 4
B	Hex Screw Lock Washer Hex Nut	1/2-13 X 2-1/2 1/2 1/2-13	6 6 6	5/8-11 X 3 5/8 5/8-11	6 6 6
C	Hex Screw Lock Washer	1/2-13 X 1-3/4 1/2	6 6	5/8-11 X 2 5/8	6 6
D	Socket Head Screw Lock Washer	3/8-16 X 1 3/8	4 4	1/2-13 X 1-1/4 1/2	4 4
E	Hex Screw Lock Washer	1/2-13 X 1-3/4 1/2	6 6	5/8-11 X 2 5/8	6 6
F	Hex Screw Lock Washer Hex Nut	1/2-13 X 2-3/4 1/2 1/2-13	6 6 6	5/8-11 X 3 5/8 5/8-11	6 6 6
G	Hex Screw Lock Washer	1/2-13 X 1-1/2 1/2	6 6	5/8-11 X 1-1/2 5/8	6 6
H	Hex Screw Lock Washer	1/4-20 X 7/8 1/4	4 4	5/16-18 X 1 5/16	4 4

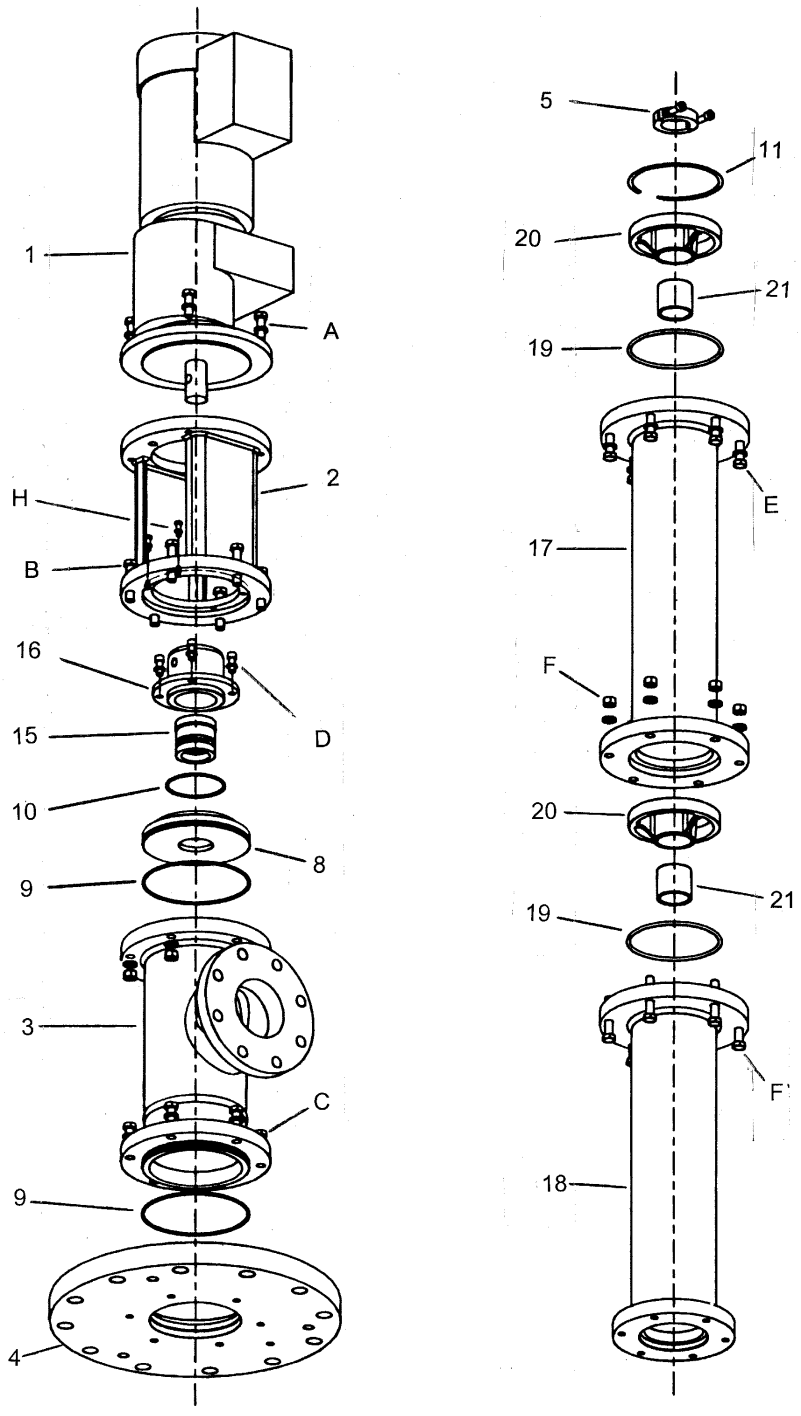

Figure 4-3a Pump Exploded View

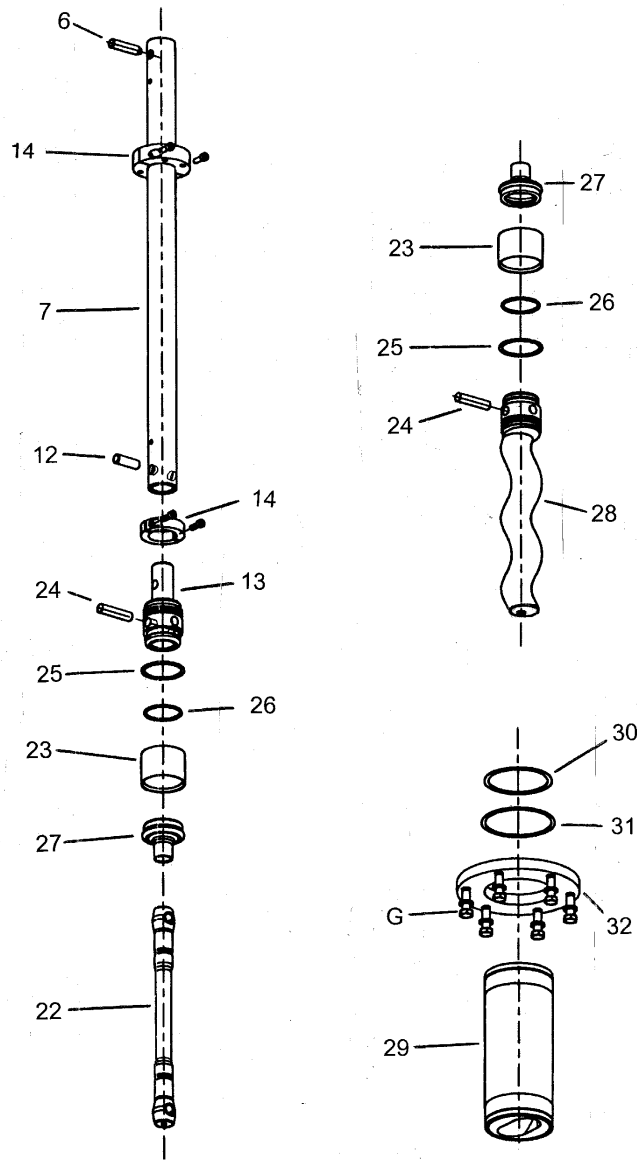

Figure 4-3b Pump Exploded View

**REPLACEMENT PARTS  
FOR V1F, V2F, V4F, V1G, V2G, V4G**

REF. #	PART NUMBER	DESCRIPTION
1	---	See Nameplate
2	4250945001	Drive Adapter
3	4250943001 4250943004	Discharge Housing – Alloy Steel Discharge Housing – Stainless Steel
4	4250900001 4250090004	Mounting Flange – Alloy Steel Mounting Flange – Stainless Steel
5	4241190001	Shaft Collar
6	4220622001	Drive Pin
7	4250925001	Drive Shaft
8	4241164001 4241164004	Seal Adapter Plate – Alloy Steel Seal Adapter Plate – Stainless Steel
9	3207902261	O-Ring – Nitrile
10	3207902239	O-Ring – Nitrile
11	6010540600	Retaining Ring
12	4220616001 4220616017	Drive Pin – Alloy Steel Drive Pin – Stainless Steel
13	4250863001 4250863015	Shaft Head – Alloy Steel Shaft Head – Stainless Steel
14	4230607004	Shaft Collar
15	4220626001	Single Mechanical Seal – Duro RO
16	4250947001 4250947004	Seal Housing – Alloy Steel Seal Housing – Stainless Steel
17	4250794023 4250795023 4250794040 4250795040	Extension Tube – “F” size – Alloy Steel Extension Tube – “F” size -Stainless Steel Extension Tube – “G” size – Alloy Steel Extension Tube – “G” size -Stainless Steel
18	4250859060 4250860060	Extension Tube – Alloy Steel Extension Tube – Stainless Steel
19	3207902360	O-Ring – Nitrile
20	4250869001	Bearing Flange
21	4220614001	Shaft Bushing
22	AS A1F6200 SS A1F6200 AS A1G6200 SS A1G6200	Connecting Rod – Alloy Steel Connecting Rod – Stainless Steel Connecting Rod – Alloy Steel Connecting Rod – Stainless Steel
23	ST A1F6100 ST A1G6100	Pin Retaining Ring Pin Retaining Ring
24	TR A1F6300 TR A1G6300	Drive Pin Drive Pin
25	EB536 EB545	Retaining Ring – F Retaining Ring - G
26	CA188 CA197	O-Ring – Nitrile - F O-Ring – Nitrile – G
27	RD A1F6400 RD A1G6400	Pin Joint Seal - Nitrile Pin Joint Seal – Nitrile
30	GG A1F1200 GG A1G1200	Stator Gasket – Nitrile Stator Gasket - Nitrile
31	EC055 4052000215 EC060 4062000215	Retaining Ring – F - Alloy Steel Retaining Ring – G -Stainless Steel Retaining Ring – F – Alloy Steel Retaining Ring – G – Stainless Steel
32	MS A1F1810 4230627004 MS A1G1810 4230628004	Clamp Ring – Alloy Steel Clamp Ring – Stainless Steel Clamp Ring – Alloy Steel Clamp Ring – Stainless Steel

**REPLACEMENT PARTS  
FOR V1H, V2H, V4H, V1J, V2J, V1K, V2K, V1L, V2L**

REF. #	PART NUMBER	DESCRIPTION
1	---	See Nameplate
2	4250946001	Drive Adapter
3	4250944001 4250944004	Discharge Housing – Alloy Steel Discharge Housing – Stainless Steel
4	4250808001 4250808004	Mounting Flange – Alloy Steel Mounting Flange – Stainless Steel
5	4241191001	Shaft Collar
6	4220623001	Drive Pin
7	4250927001	Drive Shaft
8	4241189001 4241189004	Seal Adapter Plate – Alloy Steel Seal Adapter Plate – Stainless Steel
9	3207902269	O-Ring – Nitrile
10	3207902248	O-Ring – Nitrile
11	6010540900	Retaining Ring
12	4220617001 4220617017	Drive Pin – Alloy Steel Drive Pin – Stainless Steel
13	4250865001 4250865015	Shaft Head – Alloy Steel Shaft Head – Stainless Steel
14	4230607104	Shaft Collar
15	4220626002	Single Mechanical Seal – Duro RO
16	4250948001 4250948004	Seal Housing – Alloy Steel Seal Housing – Stainless Steel
17	4250917040 4250918040	Extension Tube – Alloy Steel Extension Tube – Stainless Steel
18	4250920060 4250921060	Extension Tube – Alloy Steel Extension Tube – Stainless Steel
19	3207902372	O-Ring – Nitrile
20	4250872001	Bearing Flange
21	4220614002	Shaft Bushing
22	AS A1H6200 SS A1H6200	Connecting Rod – Alloy Steel Connecting Rod – Stainless Steel
23	ST AIH6100	Pin Retaining Ring
24	TR A1H6300	Drive Pin
25	EB549	Retaining Ring
26	CA228	O-Ring – Nitrile
27	RD A1H6400	Pin Joint Seal - Nitrile
30	GG A1H1200	Stator Gasket - Nitrile
31	EC065 4072000415	Retaining Ring – Alloy Steel Retaining Ring – Stainless Steel
32	MS A1H1810 4230629004	Clamp Ring – Alloy Steel Clamp Ring – Stainless Steel

4-18c. Parts List

**REPLACEMENT PARTS — ROTORS**  
**Ref. # 28**

<b>TOOL STEEL</b>				
<b>MODEL</b>	<b>CHROME PLATED</b>			<b>NON-PLATED</b>
	<b>STD. P/N</b>	<b>OVR. SIZE P/N</b>	<b>UND. SIZE P/N</b>	<b>STD. P/N</b>
V1F	TS A1F5000	TS A1F5200	TS A1F5100	TS A1F5020
V2F	TS A2F5000	TS A2F5200	TS A2F5100	TS A2F5020
V4F	TS A4F5000	TS A4F5200	TS A4F5100	TS A4F5020
V1G	TS A1G5000	TS A1G5200	TS A1G5100	TS A1G5020
V2G	TS A2G5000	TS A2G5200	TS A2G5100	TS A2G5020
V4G	TS A4G5000	TS A4G5200	TS A4G5100	TS A4G5020
V1H	TS A1H5000	TS A1H5200	TS A1H5100	TS A1H5020
V2H	TS A2H5000	TS A2H5200	TS A2H5100	TS A2H5020
V4H	TS A4H5000	TS A4H5200	TS A4H5100	TS A4H5020
V1J	TS A1J5000	TS A1J5200	TS A1J5100	TS A1J5020
V2J	TS A2J5000	TS A2J5200	TS A2J5100	TS A2J5020
V1K	TS A1K5000	TS A1K5200	TS A1K5100	TS A1K5020
V2K	TS A2K5000	TS A2K5200	TS A2K5100	TS A2K5020
V1L	TS A1L5000	TS A1L5200	TS A1L5100	TS A1L5020
V2L	TS A2L5000	TS A2L5200	TS A2L5100	TS A2L5020

<b>STAINLESS STEEL</b>				
<b>MODEL</b>	<b>CHROME PLATED</b>			<b>NON-PLATED</b>
	<b>STD. P/N</b>	<b>OVR. SIZE P/N</b>	<b>UND. SIZE P/N</b>	<b>STD. P/N</b>
V1F	SS A1F5000	SS A1F5200	SS A1F5100	SS A1F5020
V2F	SS A2F5000	SS A2F5200	SS A2F5100	SS A2F5020
V4F	SS A4F5000	SS A4F5200	SS A4F5100	SS A4F5020
V1G	SS A1G5000	SS A1G5200	SS A1G5100	SS A1G5020
V2G	SS A2G5000	SS A2G5200	SS A2G5100	SS A2G5020
V4G	SS A4G5000	SS A4G5200	SS A4G5100	SS A4G5020
V1H	SS A1H5000	SS A1H5200	SS A1H5100	SS A1H5020
V2H	SS A2H5000	SS A2H5200	SS A2H5100	SS A2H5020
V4H	SS A4H5000	SS A4H5200	SS A4H5100	SS A4H5020
V1J	SS A1J5000	SS A1J5200	SS A1J5100	SS A1J5020
V2J	SS A2J5000	SS A2J5200	SS A2J5100	SS A2J5020
V1K	SS A1K5000	SS A1K5200	SS A1K5100	SS A1K5020
V2K	SS A2K5000	SS A2K5200	SS A2K5100	SS A2K5020
V1L	SS A1L5000	SS A1L5200	SS A1L5100	SS A1L5020
V2L	SS A2L5000	SS A2L5200	SS A2L5100	SS A2L5020

**REPLACEMENT PARTS — STATORS**  
**Ref. #29**

<b>ALLOY STEEL TUBING</b>				
<b>MODEL</b>	<b>Q (NITRILE) P/N</b>	<b>R (NATURAL) P/N</b>	<b>B (EPDM) P/N</b>	<b>F (FLUORO) P/N</b>
V1F	RQ A1F6510	RR A1F6510	RB A1F6510	RF A1F6510
V2F	RQ A2F6510	RR A2F6510	RB A2F6510	RF A2F6510
V4F	RQ A4F6510	RR A4F6510	RB A4F6510	RF A4F6510
V1G	RQ A1G6510	RR A1G6510	RB A1G6510	RF A1G6510
V2G	RQ A2G6510	RR A2G6510	RB A2G6510	RF A2G6510
V4G	RQ A4G6510	RR A4G6510	RB A4G6510	RF A4G6510
V1H	RQ A1H6510	RR A1H6510	RB A1H6510	RF A1H6510
V2H	RQ A2H6510	RR A2H6510	RB A2H6510	RF A2H6510
V4H	RQ A4H6510	RR A4H6510	RB A4H6510	RF A4H6510
V1J	RQ A1J6510	RR A1J6510	RB A1J6510	RF A1J6510
V2J	RQ A2J6510	RR A2J6510	RB A2J6510	RF A2J6510
V1K	RQ A1K6510	RR A1K6510	RB A1K6510	RF A1K6510
V2K	RQ A2K6510	RR A2K6510	RB A2K6510	RF A2K6510
V1L	RQ A1L6510	RR A1L6510	RB A1L6510	RF A1L6510
V2L	RQ A2L6510	RR A2L6510	RB A2L6510	RF A2L6510

<b>STAINLESS STEEL TUBING</b>				
<b>MODEL</b>	<b>Q (NITRILE) P/N</b>	<b>R (NATURAL) P/N</b>	<b>B (EPDM) P/N</b>	<b>F (FLUORO) P/N</b>
V1F	SQ A1F6510	SR A1F6510	SB A1F6510	SF A1F6510
V2F	SQ A2F6510	SR A2F6510	SB A2F6510	SF A2F6510
V4F	SQ A4F6510	SR A4F6510	SB A4F6510	SF A4F6510
V1G	SQ A1G6510	SR A1G6510	SB A1G6510	SF A1G6510
V2G	SQ A2G6510	SR A2G6510	SB A2G6510	SF A2G6510
V4G	SQ A4G6510	SR A4G6510	SB A4G6510	SF A4G6510
V1H	SQ A1H6510	SR A1H6510	SB A1H6510	SF A1H6510
V2H	SQ A2H6510	SR A2H6510	SB A2H6510	SF A2H6510
V4H	SQ A4H6510	SR A4H6510	SB A4H6510	SF A4H6510
V1J	SQ A1J6510	SR A1J6510	SB A1J6510	SF A1J6510
V2J	SQ A2J6510	SR A2J6510	SB A2J6510	SF A2J6510
V1K	SQ A1K6510	SR A1K6510	SB A1K6510	SF A1K6510
V2K	SQ A2K6510	SR A2K6510	SB A2K6510	SF A2K6510
V1L	SQ A1L6510	SR A1L6510	SB A1L6510	SF A1L6510
V2L	SQ A2L6510	SR A2L6510	SB A2L6510	SF A2L6510

**Your Moyno Authorized Service Distributor is:**